

1) Duct Flow: Use ANSYS Workbench/FLUENT and develop a grid and analyze the flow in a pipe contraction. The inlet pipe has a diameter of 4 cm with a length of 8 cm. The outlet pipe has a diameter of 2 cm and is 6 cm long. a) For an air velocity of 0.01 m/s, find the laminar flow solution. b) For an air velocity of 5 m/s, evaluate the velocity profile and turbulence conditions using different turbulence models, and discuss the differences. c) Evaluate the capture efficiency of the pipe contractions for different particle sizes for different cases.

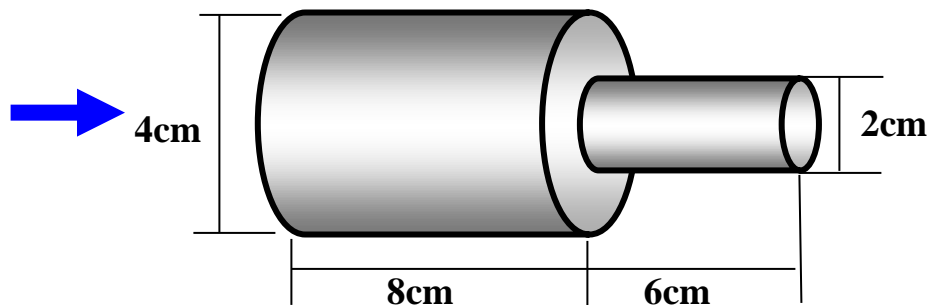

2) Sphere: a) Use ANSYS Workbench/FLUENT and solve the flow around a sphere of radius 1 mm in cross-flow velocities of 0.01, 0.1, and 1 mm/s. Compare the results with the exact creeping flow results. B) Repeat the problem for a 10 cm sphere with a cross-flow of 5 m/s. For the case of turbulent flow, use different turbulent models, and compare the results. c) Find the drag force acting on the sphere. Plot the drag coefficient versus the Reynolds number and compare it with the empirical models. d) Evaluate the capture efficiency of the sphere for different size particles for different cases.

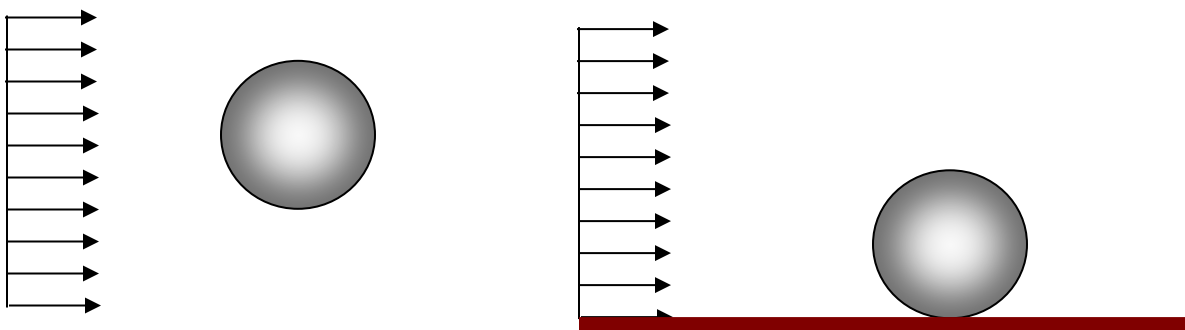

3) Sphere attached to a Plane: Repeat Problem 2 when the sphere is attached to a wall.

Reports and Due Dates: The reports should include hard copies of the figures and a discussion of the results. A CD containing the report and computational code, FLUENT CAS, and DAT files should be submitted with the report. The due date is April 24, 2023.

Select and analyze a realistic three-D turbulent flow and particle transport project of practical interest. Discuss with the instructor your selected project.

Examples are:

- a) Flow around a car and dispersion from the exhaust.
- b) Flow and virus dispersion in a classroom.
- c) Flow and aerosol transport and deposition in a street canyon.
- d) Particle transport and deposition in rough ducts
- e) Aerosol transport in buildings.
- f) Flow and pollutant transport around a building and through building envelop.
- g) Aerosols transport in cities.
- h) Aerosol transport and deposition in the mouth and larynx during breathing.
- i) Aerosol transport and deposition in the upper lung airways during breathing.
- j) Aerosol transport in the lung's alveolar cavity during breathing.
- k) Blood flows in arteries.
- l) Modeling of particle deposition in an aerodynamic lens.
- m) Filtration systems.
- n) Saturn Ring.
- o) Formation of stars.
- p) Coagulation of colloidal particles. Application to production of mono-dispersed particles.

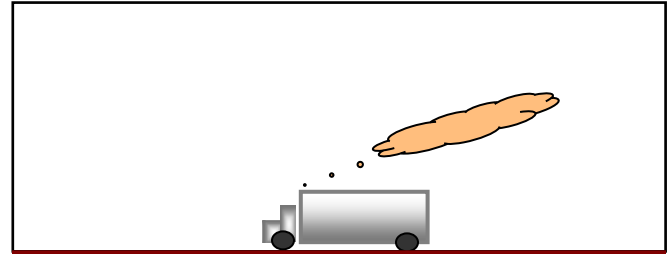

Report and Due Dates: The reports should include hard copies and electronic copies of the programs, figures, and discussion of the results. The due date is April 24, 2023.